

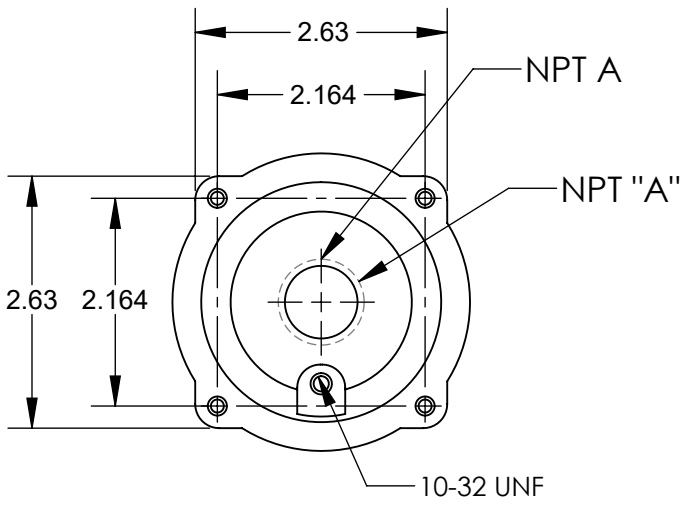

This drawing is the property of MELTRIC Corporation, Franklin (Milwaukee) Wisconsin, USA. Any unauthorized copying of this drawing by any means, ENG/RD/06 REV: 20 ISSUED DATE: 1/15/11 or disclosure of its contents to any person not authorized by MELTRIC Corporation or its agents to receive it, is strictly prohibited.

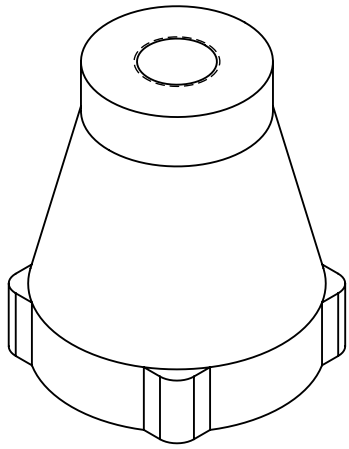
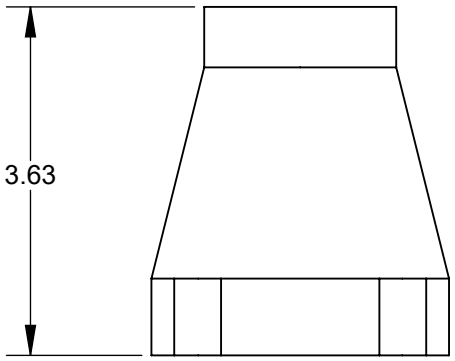

| PART NUMBER | NPT "A" |
|-------------|------------|
| 593P0N05 | 1/2" NPT |
| 593P0N07 | 3/4" NPT |
| 593P0N10 | 1" NPT |
| 593P0N12 | 1-1/4" NPT |

TOLERANCES UNLESS OTHERWISE SPECIFIED

| | |
|---------------------------------------------------------------------------------------------------------------------------------------------------------------------------------------------------------------------------------------------------------------------------------------------------------------------------------------------------------------------------|------------------------------------------------------------------------------------------------------------------------------|
| <p>MACHINED SURFACES $\sqrt[125]{\text{MAX}}$</p> <p>GROUND SURFACES $\sqrt[32]{\text{MAX}}$</p> <p>ANGLE TOLERANCE $\pm 1^\circ$</p> <p>REMOVE BURRS & SHARP EDGES TO .015 MAX.</p> <p> DIMENSIONS SHOWN IN OVALS ARE INSPECTION DIMENSIONS.</p> | <p>ENGLISH</p> <p>0.X ± 0.05</p> <p>0.XX ± 0.01</p> <p>0.XXX ± 0.005</p> |
|---------------------------------------------------------------------------------------------------------------------------------------------------------------------------------------------------------------------------------------------------------------------------------------------------------------------------------------------------------------------------|------------------------------------------------------------------------------------------------------------------------------|

MELTRIC
A COMPANY OF MARÉCHAL ÉLECTRIC

| | | | |
|--------|-------------|------------------------------|----------|
| DRAWN | APPROVED | DRAWING TITLE: | |
| | | METAL THREADED HANDLE | |
| DATE: | SCALE: | MATERIAL: | |
| | NTS | PAINTED METAL | |
| SHEET: | PART NUMBER | | REVISION |
| 1 OF 1 | 593P0Nxx | | |